

Fostex®

LOW LEAKAGE FLUX TYPE FULL RANGE SPEAKER UNIT

FE87E

Features

- 'ES cone' paper made of banana plant's fiber
- Newly designed center cap
- Repulsion type magnetically shielded circuit
- Ferrite magnet

Specifications

&

Thiele/Small Parameters

Size	:	80 mm / 3 in
Voice Coil Diameter	:	16 mm / 0.6 in
Cast / Stamped	:	Stamped
Impedance	:	8 Ω
Reproduction Frequency Response	:	:fs - 30 kHz
Sound Pressure Level	:	89 dB/W(m)
Rated Input	:	5 W
Music Power	:	10 W
Magnet Material	:	Ferrite
Magnet Weight	:	
(main)	:	48.4 g / 0.107 lb
(cancel)	:	27.9 g / 0.062 lb
Net Weight	:	288 g / 0.635 lb

a	:	30 mm
D	:	60 mm
Sd	:	0.00283 m ²
Zn	:	8 Ω
Fs	:	140 Hz
Re	:	7.7 Ω
Le	:	n/a mH
Qms	:	3.77
Qes	:	1.20
Qts	:	0.92
Mms	:	1.4 g
BL	:	2.81 Telsa/m
Vas	:	1.03 L
Xmax	:	0.40 mm
Eff/η0	:	0.22 %
Cms	:	0.00092 mm/N
EBP	:	117



Frequency Response / Impedance

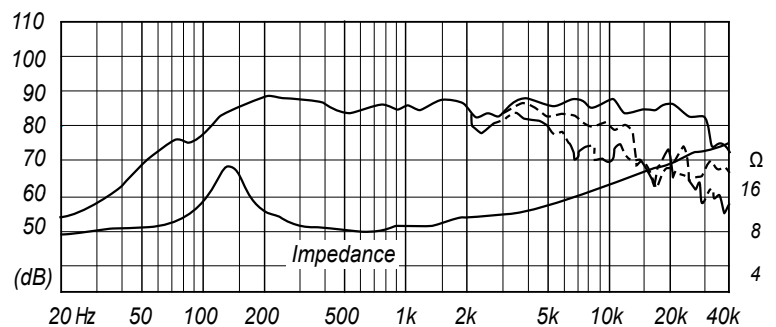

Dimensions & Mounting Information

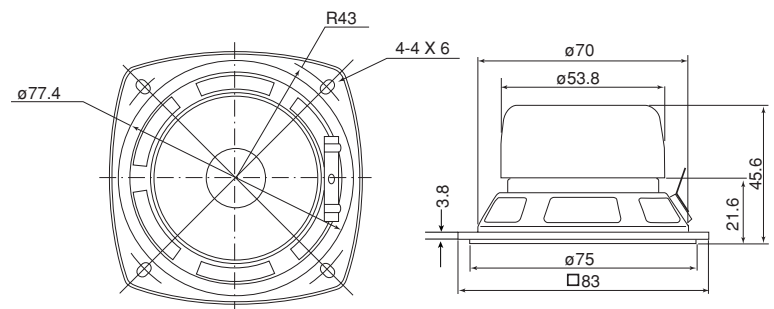

Overall Diameter	:	83 mm / 3.3 in
Baffle Hole Diameter	:	75 mm / 2.8 in
Depth	:	45.6 mm / 1.8 in

FE87E

Recommended Back Loaded Horn Type Enclosure

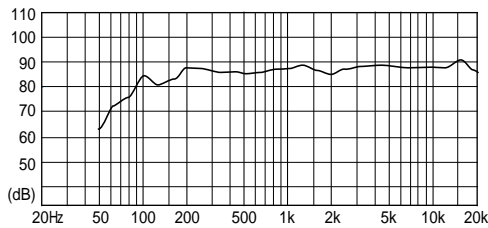
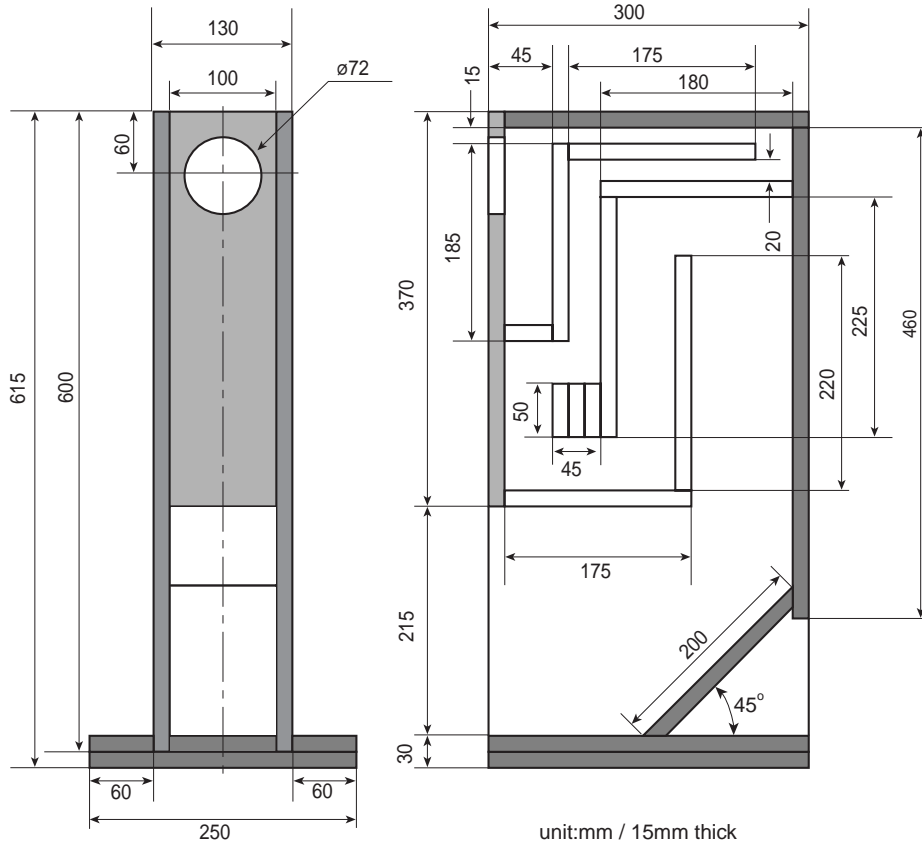

- This example shows a back loaded horn type enclosure for FE87E.
- Simple design constructed with flat panels.
- This enclosure provides rich low frequency through the horn and mixes high/mid frequency radiated directly from the FE87E for clarity of total sound image.

Recommended Standard Bass Reflex Type Enclosure

Example of FE87E standard bass reflex type enclosure. Internal volume is 5 liters tuned to approximately 99Hz (Fb).

